

Features

- Single 2.5V or 2.7V to 3.6V Supply
- RapidS[®] Serial Interface: 66 MHz Maximum Clock Frequency
 - SPI Compatible Modes 0 and 3
- User Configurable Page Size
 - 256 Bytes per Page
 - 264 Bytes per Page
 - Page Size Can Be Factory Pre-configured for 256 Bytes
- Page Program Operation
 - Intelligent Programming Operation
 - 4,096 Pages (256/264 Bytes/Page) Main Memory
- Flexible Erase Options
 - Page Erase (256 Bytes)
 - Block Erase (2 Kbytes)
 - Sector Erase (64 Kbytes)
 - Chip Erase (8 Mbits)
- Two SRAM Data Buffers (256/264 Bytes)
 - Allows Receiving of Data while Reprogramming the Flash Array
- Continuous Read Capability through Entire Array
 - Ideal for Code Shadowing Applications
- Low-power Dissipation
 - 7 mA Active Read Current Typical
 - 25 μ A Standby Current Typical
 - 5 μ A Deep Power Down Typical
- Hardware and Software Data Protection Features
 - Individual Sector
- Sector Lockdown for Secure Code and Data Storage
 - Individual Sector
- Security: 128-byte Security Register
 - 64-byte User Programmable Space
 - Unique 64-byte Device Identifier
- JEDEC Standard Manufacturer and Device ID Read
- 100,000 Program/Erase Cycles Per Page Minimum
- Data Retention – 20 Years
- Industrial Temperature Range
- Green (Pb/Halide-free/RoHS Compliant) Packaging Options

1. Description

The AT45DB081D is a 2.5V or 2.7V, serial-interface Flash memory ideally suited for a wide variety of digital voice-, image-, program code- and data-storage applications. The AT45DB081D supports RapidS serial interface for applications requiring very high speed operations. RapidS serial interface is SPI compatible for frequencies up to 66 MHz. Its 8,650,752 bits of memory are organized as 4,096 pages of 256 bytes or 264 bytes each. In addition to the main memory, the AT45DB081D also contains two SRAM buffers of 256/264 bytes each. The buffers allow the receiving of data while a page in the main Memory is being reprogrammed, as well as writing a continuous data stream. EEPROM emulation (bit or byte alterability) is easily handled with a self-contained three step read-modify-write operation. Unlike conventional Flash memories that are accessed randomly with multiple address lines and a parallel interface,



**8-megabit
2.5-volt or
2.7-volt
DataFlash[®]**

AT45DB081D



the DataFlash uses a RapidS serial interface to sequentially access its data. The simple sequential access dramatically reduces active pin count, facilitates hardware layout, increases system reliability, minimizes switching noise, and reduces package size. The device is optimized for use in many commercial and industrial applications where high-density, low-pin count, low-voltage and low-power are essential.

To allow for simple in-system reprogrammability, the AT45DB081D does not require high input voltages for programming. The device operates from a single power supply, 2.5V to 3.6V or 2.7V to 3.6V, for both the program and read operations. The AT45DB081D is enabled through the chip select pin (\overline{CS}) and accessed via a three-wire interface consisting of the Serial Input (SI), Serial Output (SO), and the Serial Clock (SCK).

All programming and erase cycles are self-timed.

2. Pin Configurations and Pinouts

Figure 2-1. MLF (VDFN) Top View

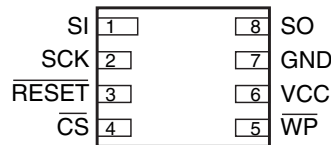
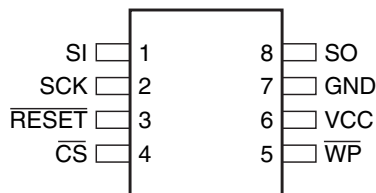

Figure 2-2. SOIC Top View



Note: 1. The metal pad on the bottom of the MLF package is floating. This pad can be a “No Connect” or connected to GND.

18. Electrical Specifications

Table 18-1. Absolute Maximum Ratings*

Temperature under Bias	-55° C to +125° C
Storage Temperature	-65° C to +150° C
All Input Voltages (including NC Pins) with Respect to Ground	-0.6V to +6.25V
All Output Voltages with Respect to Ground	-0.6V to $V_{CC} + 0.6V$

*NOTICE: Stresses beyond those listed under “Absolute Maximum Ratings” may cause permanent damage to the device. This is a stress rating only and functional operation of the device at these or any other conditions beyond those indicated in the operational sections of this specification is not implied. Exposure to absolute maximum rating conditions for extended periods may affect device reliability.

Table 18-2. DC and AC Operating Range

		AT45DB081D (2.5V Version)	AT45DB081D
Operating Temperature (Case)	Ind.	-40° C to 85° C	-40° C to 85° C
V_{CC} Power Supply		2.5V to 3.6V	2.7V to 3.6V

Note: 1. After power is applied and V_{CC} is at the minimum specified datasheet value, the system should wait 10 ms before an operational mode is started.

Table 18-3. DC Characteristics

Symbol	Parameter	Condition	Min	Typ	Max	Units
I_{DP}	Deep Power-down Current	\overline{CS} , \overline{RESET} , $\overline{WP} = V_{IH}$, all inputs at CMOS levels		5	10	μA
I_{SB}	Standby Current	\overline{CS} , \overline{RESET} , $\overline{WP} = V_{IH}$, all inputs at CMOS levels		25	50	μA
$I_{CC1}^{(1)}$	Active Current, Read Operation	f = 20 MHz; $I_{OUT} = 0$ mA; $V_{CC} = 3.6V$		7	10	mA
		f = 33 MHz; $I_{OUT} = 0$ mA; $V_{CC} = 3.6V$		8	12	mA
		f = 50 MHz; $I_{OUT} = 0$ mA; $V_{CC} = 3.6V$		10	14	mA
		f = 66 MHz; $I_{OUT} = 0$ mA; $V_{CC} = 3.6V$		11	15	mA
I_{CC2}	Active Current, Program/Erase Operation	$V_{CC} = 3.6V$		12	17	mA
I_{LI}	Input Load Current	$V_{IN} =$ CMOS levels			1	μA
I_{LO}	Output Leakage Current	$V_{IO} =$ CMOS levels			1	μA
V_{IL}	Input Low Voltage				$V_{CC} \times 0.3$	V
V_{IH}	Input High Voltage		$V_{CC} \times 0.7$			V
V_{OL}	Output Low Voltage	$I_{OL} = 1.6$ mA; $V_{CC} = 2.7V$			0.4	V
V_{OH}	Output High Voltage	$I_{OH} = -100$ μA	$V_{CC} - 0.2V$			V

Notes: 1. I_{CC1} during a buffer read is 20 mA maximum @ 20 MHz.
2. All inputs are 5 volts tolerant.

Table 18-4. AC Characteristics – RapidS/Serial Interface

Symbol	Parameter	AT45DB081D (2.5V Version)			AT45DB081D			Units
		Min	Typ	Max	Min	Typ	Max	
f_{SCK}	SCK Frequency			50			66	MHz
f_{CAR1}	SCK Frequency for Continuous Array Read			50			66	MHz
f_{CAR2}	SCK Frequency for Continuous Array Read (Low Frequency)			33			33	MHz
t_{WH}	SCK High Time	6.8			6.8			ns
t_{WL}	SCK Low Time	6.8			6.8			ns
$t_{SCKR}^{(1)}$	SCK Rise Time, Peak-to-Peak (Slew Rate)	0.1			0.1			V/ns
$t_{SCKF}^{(1)}$	SCK Fall Time, Peak-to-Peak (Slew Rate)	0.1			0.1			V/ns
t_{CS}	Minimum \overline{CS} High Time	50			50			ns
t_{CSS}	\overline{CS} Setup Time	5			5			ns
t_{CSH}	\overline{CS} Hold Time	5			5			ns
t_{SU}	Data In Setup Time	2			2			ns
t_H	Data In Hold Time	3			3			ns
t_{HO}	Output Hold Time	0			0			ns
t_{DIS}	Output Disable Time			8			6	ns
t_V	Output Valid			8			6	ns
t_{WPE}	\overline{WP} Low to Protection Enabled			1			1	μ s
t_{WPD}	\overline{WP} High to Protection Disabled			1			1	μ s
t_{EDPD}	\overline{CS} High to Deep Power-down Mode			3			3	μ s
t_{RDPD}	\overline{CS} High to Standby Mode			35			35	μ s
t_{XFR}	Page to Buffer Transfer Time			200			200	μ s
t_{comp}	Page to Buffer Compare Time			200			200	μ s
t_{EP}	Page Erase and Programming Time (256/264 bytes)		14	35		14	35	ms
t_P	Page Programming Time (256/264 bytes)		2	4		2	4	ms
t_{PE}	Page Erase Time (256/264 bytes)		13	32		13	32	ms
t_{BE}	Block Erase Time (2,048/2,112 bytes)		30	75		30	75	ms
t_{SE}	Sector Erase Time (65,536/67,584)		1.6	5		1.6	5	s
t_{CE}	Chip Erase Time		TBD	TBD		TBD	TBD	s
t_{RST}	\overline{RESET} Pulse Width	10			10			μ s
t_{REC}	\overline{RESET} Recovery Time			1			1	μ s

26. Ordering Information

26.1 Ordering Code Detail

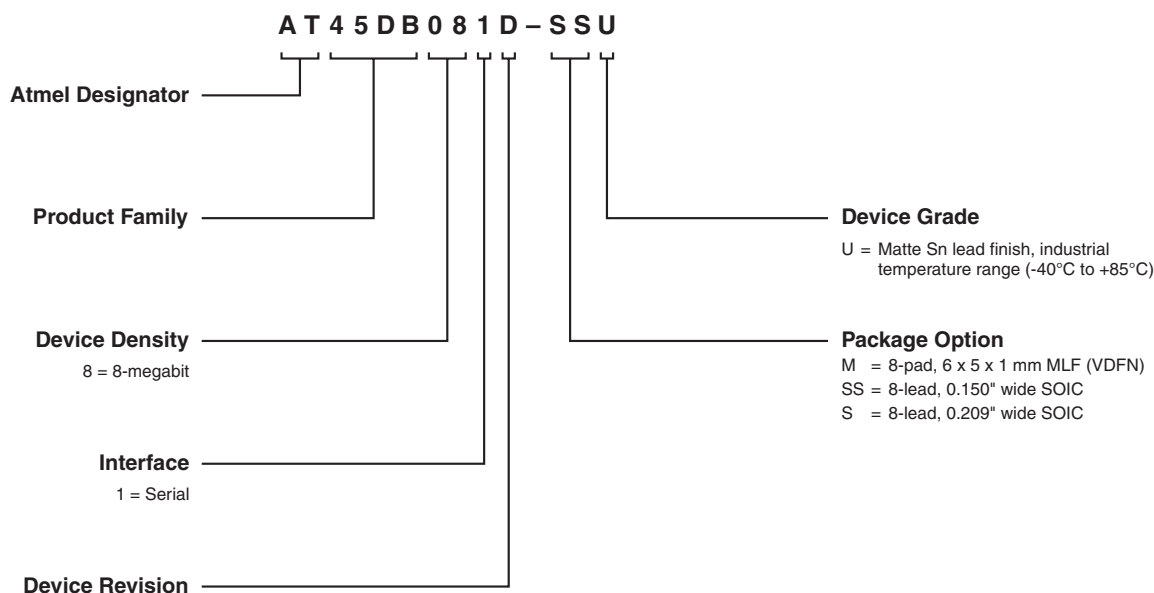

26.2 Green Package Options (Pb/Halide-free/RoHS Compliant)

Ordering Code ⁽¹⁾⁽²⁾	Package	Lead Finish	Operating Voltage	f _{SCK} (MHz)	Operation Range
AT45DB081D-MU AT45DB081D-MU-SL954 ⁽³⁾ AT45DB081D-MU-SL955 ⁽⁴⁾	8M1-A	Matte Sn	2.7V to 3.6V	66	Industrial (-40°C to 85°C)
AT45DB081D-SSU AT45DB081D-SSU-SL954 ⁽³⁾ AT45DB081D-SSU-SL955 ⁽⁴⁾	8S1				
AT45DB081D-SU AT45DB081D-SU-SL954 ⁽³⁾ AT45DB081D-SU-SL955 ⁽⁴⁾	8S2				
AT45DB081D-MU-2.5	8M1-A	Matte Sn	2.5V to 3.6V	50	
AT45DB081D-SSU-2.5	8S1				
AT45DB081D-SU-2.5	8S2				

- Notes:
- The shipping carrier option is not marked on the devices.
 - Standard parts are shipped with the page size set to 264 bytes. The user is able to configure these parts to a 256-byte page size if desired.
 - Parts ordered with suffix SL954 are shipped in bulk with the page size set to 256 bytes. Parts will have a 954 or SL954 marked on them.
 - Parts ordered with suffix SL955 are shipped in tape and reel with the page size set to 256 bytes. Parts will have a 954 or SL954 marked on them.

Package Type	
8M1-A	8-pad, 6 x 5 x 1.00 mm Body, Very Thin Dual Flat Package No Lead MLF™ (VDFN)
8S1	8-lead, 0.150" Wide, Plastic Gull Wing Small Outline Package (JEDEC SOIC)
8S2	8-lead, 0.209" Wide, Plastic Gull Wing Small Outline Package (EIAJ SOIC)

27.2 8S1 – JEDEC SOIC

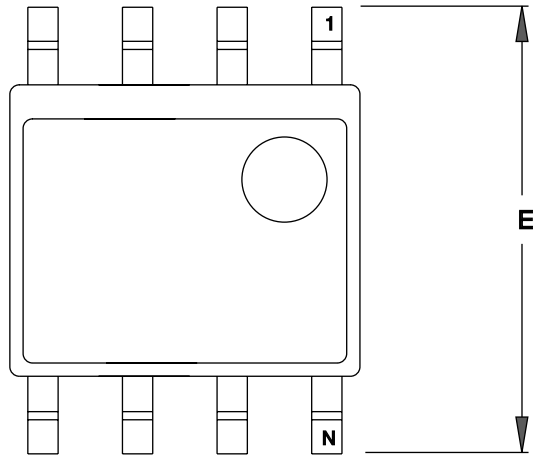

TOP VIEW

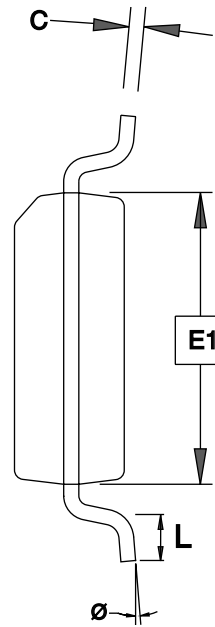

END VIEW

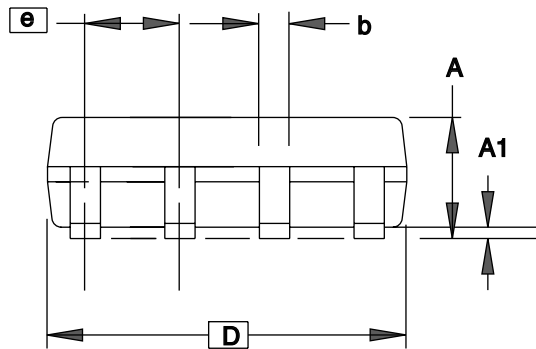

SIDE VIEW

COMMON DIMENSIONS
(Unit of Measure = mm)

SYMBOL	MIN	NOM	MAX	NOTE
A	1.35	–	1.75	
A1	0.10	–	0.25	
b	0.31	–	0.51	
C	0.17	–	0.25	
D	4.80	–	5.05	
E1	3.81	–	3.99	
E	5.79	–	6.20	
e	1.27 BSC			
L	0.40	–	1.27	
θ	0°	–	8°	

Note: These drawings are for general information only. Refer to JEDEC Drawing MS-012, Variation AA for proper dimensions, tolerances, datums, etc.



1150 E. Cheyenne Mtn. Blvd.
Colorado Springs, CO 80906

TITLE
8S1, 8-lead (0.150" Wide Body), Plastic Gull Wing
Small Outline (JEDEC SOIC)

DRAWING NO.
8S1

REV.
C